



NU-VU® Model:

# SB-1 & SB-2

Knock Down Rack

*A Quality Product Made in the U.S.A.*

by:

**NU-VU® Food Service Systems**

5600 13<sup>th</sup> STREET

MENOMINEE, MICHIGAN 49858-1029

(906) 863-4401 FAX(sales) (906) 863-5889

(800) 338-9886 FAX(service) (906) 863-6332

Revised:

January 22<sup>nd</sup>, 2026

(This page is intentionally left blank)

Dear Customer:

Thank you for buying NU-VU® equipment. We think you have purchased one of the best units on the market today.

Every piece of NU-VU® equipment is put through a full electrical test. In addition, NU-VU® ovens are randomly selected for test baking to ensure you are receiving the best product possible. The interior of the oven may darken slightly during this testing process. This coloration is normal and occurs in any oven that has been operated for a few hours. It will not affect the operation, durability or warranty of your NU-VU® equipment.

This OWNER'S MANUAL has been put together to give you a good general knowledge of your equipment. It is not a detailed technical manual; such a book is unnecessary for the daily care and operation of your unit. However, this Manual *does* contain some basic trouble-shooting and service information. If this OWNER'S MANUAL does not answer your questions or solve your problems please call us at (906) 863-4401. You can also fax your question or comment to our Service Department at (906) 863-6322 or Toll Free at (800) 338-9886. You can even e-mail us at [service@nu-vu.com](mailto:service@nu-vu.com). One of our service technicians will be glad to assist you. Please remember to supply the model number and serial number of your NU-VU® equipment when you contact us. When calling for service or parts, try to be at the equipment location so that we can better assist you with your service or parts needs.

Each page carries information to help you use this OWNER'S MANUAL. The header at the top of each page contains the title of the section you are currently in. The footer at the bottom of each page carries the page number, our telephone number, and our Sales and Service fax numbers.

All sections begin at the top of a page and start like this:

## SECTION HEADING

All sub-section headings are on the left side of each page and look like this:

### SUB-SECTION HEADING:

#### SUB-SECTION HEADING - -

**IMPORTANT: THESE SHADED BOXES WILL CONTAIN IMPORTANT WARNING,  
OPERATING AND/OR SAFETY INFORMATION!**

The illustrations used throughout this OWNER'S MANUAL are titled in their lower left-hand corners. A complete list of these illustrations, along with their respective page numbers, can be found on page *iv* of this manual. A REPLACEMENT PARTS LIST can be found at the end of this manual. Replacement parts are listed by Reference Number. The part Reference Numbers are circled  $\bigcirc$  in the illustrations and bracketed [ ] in the text. Please note that some of the parts listed are not replaceable except as part of another assembly, but are listed for reference and identification only.

Electrical schematics are also included at the end of this OWNER'S MANUAL for use as reference aids only. Please contact our Service Department for specific electrical information.

(This page is intentionally left blank)

## **TABLE OF CONTENTS**

ABOUT YOUR SB-1 & SB-2 .....	4
SB-1 & SB-2 Specifications .....	5
RECEIPT & ASSEMBLY	
Receipt .....	6
Assembly .....	6-7
CLEANING GUIDE	
Cleaning .....	8
SERVICE AND REPLACEMENT GUIDE .....	16
NU-VU® EQUIPMENT WARRANTY	
Parts .....	9
Warranty Limitations .....	9-10
Parts Return Procedure and Conditions .....	10

## ABOUT YOUR SB-1 & SB-2

The NU-VU® SB Series Knockdown Rack is an lightweight storage solution for your baked good. Whether fresh from the oven and needing to be cooled down or a quick storage between uses. Perfect for those applications that need something simple to move around, yet rugged enough for your kitchen.

The SB-1 can hold up to seven (7) full size 18"x26" (457mm x 660mm) sheet pans, or fourteen (14) half-size 13"x18" (330mm x 457mm) sheet pans.

The SB-2 can hold up to seventeen (17) full size 18"x26" (457mm x 660mm) sheet pans, or thirty-four (34) half-size 13"x18" (330mm x 457mm) sheet pans.

SB-1 measures 31 3/8" (797mm) high, 21 1/2" (546mm) wide and 27 1/2" (699mm) deep, the entire unit takes up less than 5 square feet (0.46 square meters) of floor space.

SB-2 measures 63 3/4" (1619mm) high, 22 1/2" (572mm) wide and 27 1/2" (699mm) deep, the entire unit takes up less than 5 square feet (0.46 square meters) of floor space.

It is constructed of aluminum both inside and out. Shipped knockdown for assembly in less than 30 minutes.

The NU-VU® SB-1 & SB-2 are designed for:

- Dependability
- Low Maintenance
- Easy cleaning
- Simple assembly

**IMPORTANT: This appliance is not intended for use by persons (including children) with reduced physical, sensory or mental capabilities, or lack of experience and knowledge, unless they have been given supervision or instruction concerning use of the appliance by a person responsible for their safety.**

**Children should be supervised to ensure that they do not play with the appliance.**

## SB-1 & SB-2 SPECIFICATIONS:

### SB-1 Exterior Dimensions

Height = 31 3/8" (797mm)      Width = 21 1/2" (546mm)      Depth = 27 1/2" (699mm)

### SB-2 Exterior Dimensions

Height = 31 3/8" (797mm)      Width = 21 1/2" (546mm)      Depth = 27 1/2" (699mm)

### Capacities

SB-1 = Fourteen 13"x18" (330mm x 457mm) half size sheet pans with 3 1/4" (83mm) pan spacing  
or seven 18"x26" (457mm x 660mm) full size sheet pans with 3 1/4" (83mm) spacing

SB-2 = Thirty Four 13"x18" (330mm x 457mm) half size sheet pans with 3 1/4" (83mm) pan  
spacing or seventeen 18"x26" (330mm x 457mm) full size sheet pans with 3 1/4" (83mm) spacing

Listings/Approvals







# RECEIPT & ASSEMBLY

## RECEIPT:

It is essential to inspect the unit immediately when it arrives. NU-VU® has placed instructions on the packaging to help avoid damage in transit. However, negligent handling can produce hidden damage.

These steps should be followed:

- A. Uncrate the unit carefully and check the entire unit (top, front, back, and both sides) for any visible or hidden damage.
- B. Remove the unit from the shipping pallet and inspect the bottom (including the Casters) for any damage. Check the Casters and the drip pan holder under the unit.
- C. If any damage is noted after the driver leaves immediately contact the freight company and notify NU-VU® at (800) 338-9886 immediately after filing a freight claim.

## ASSEMBLY:

Record the Model Number and complete Serial Number of your unit in the spaces provided on page 21 of this manual. You will need these numbers if you should ever need to contact our Service Department concerning adjustments, replacement parts or other service needs. When calling for service or parts, try to be at the equipment location so that we can better assist you with your service or parts needs.

<u>REF #</u>	<u>DESCRIPTION</u>	<u>QTY</u>	<u>PART #</u>
1	Hoop Assy (SB-1)	2	06-0017
	Hoop Assy (SB-2)	2	06-0019
2	Ladder (SB-1)	2	06-0013
	Ladder (SB-2)	2	06-0018
3	Base	1	06-0112
4	Top	1	06-0030
5	Machine Screw	4	53-0025
6	Star Washer	4	53-0020
7	Acorn Nut	4	53-0045
8	Caster	4	50-0086
9	Caster Wrench	1	06-1002

### Tools Required:

- ¼" Standard Screwdriver
- ⅜" Wrench

**Step #1** Press the ends of one Hoop Assembly [1] into the square holes in the Base [3].

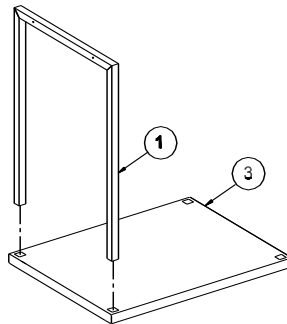

**Step #2** Fit a Ladder [2] inside the Hoop Assembly, then slide it back to lock it on the Hoop Assembly.

Repeat for the opposite side.

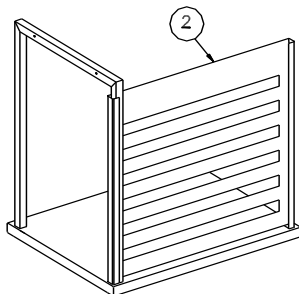

**Step #3** Slide the second Hoop Assembly inside of the Ladders and press the ends into the Base.

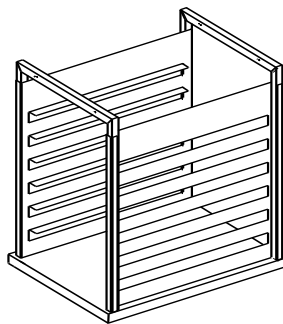

**Step #4** Attach the Top [4] to the Hoop Assemblies with the Machine Screws [5], Star Washers [6], and Acorn Nuts [7].

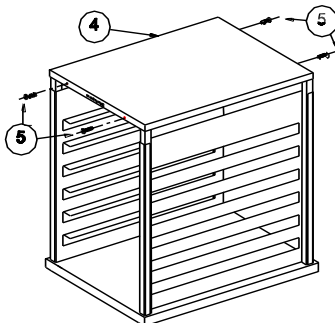

**Step #5** Turn the Cart upside down. Insert the Casters [8] through the Base and into the ends of the Hoop Assemblies. Tighten each Caster with the Caster Wrench [9] until the Caster is tight in the hole.

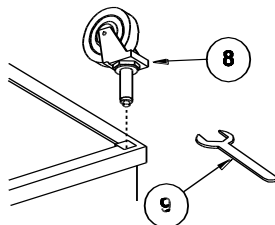

# CLEANING GUIDE

## CLEANING:

Your SB-1 & SB-2 should be cleaned daily and as soon as possible after a spill has occurred. It is essential to maintain a clean unit, especially if the public views the unit in your place of business. The following should be used for cleaning:

- A. The aluminum exterior and interior can be cleaned with a simple combination of hot water and soap. Make sure once the cabinet is cleaned that you take a clean dry rag to help dry it down. If you notice any signs of pitting contact NU-VU Food Service Systems for recommendations on how to correct.

### **\*\*\* CAUTION \*\*\***

NU-VU® DOES NOT RECOMMEND the use of any strong commercial or caustic product on this equipment. DO NOT allow any type of caustic cleaner to come into contact with any aluminum parts (such as Door Frames), the silicon rubber Door Gaskets, or any of the sealing compound in the Oven and Proofer seams and joints. These compounds may cause discoloration and degradation of these parts resulting in permanent damage. DO NOT use bleach or bleach compounds on any chromed parts; bleach will damage chrome plating. DO NOT CLEAN THIS APPLIANCE WITH A WATER JET OR PRESSURE WASHER.

## **NOTE:**

NU-VU® has had very good results with a product called JIFFY CLEANER. For standard cleaning simply spray JIFFY on and wipe off. Heavily soiled areas may require a short period of soaking. This cleaner is available through NU-VU® (Part #51-0002) or through your local Rochester/Midland distributor or representative.

# NU-VU® EQUIPMENT WARRANTY

NU-VU® products are warranted against defects in workmanship and materials from the original date of shipment only. NU-VU® does not warrant against any damage that may occur during shipment or storage of the equipment. Any claim for such damage must be filed against the carrier or storage company. No other express warranty, written or oral, applies. No person is authorized to give any other warranty or assume any other liability on behalf of NU-VU®, except by written statement from an officer of NU-VU®. Your NU-VU® equipment warranty is limited to the following time periods for the original owner only:

	<u>PARTS</u>
Inside the United States and Canada	12 Months

The NU-VU® equipment warranty is composed of the following:

## **PARTS:**

This limited warranty covers certain electrical, electronic and mechanical parts for the time periods shown above with the exception of those items detailed under Warranty Limitations. Customers who maintain an open account may purchase against their account. MasterCard, Visa and American Express credit cards are also accepted.

The return of defective parts is required. An RGA # is required for parts being returned. The return of a defective part or component must be made prior to the issuance of a credit on an open account. If a part that is returned tests satisfactory in the NU-VU® factory or at an authorized NU-VU® dealer or service agency, NU-VU® may withhold issuing credit. Replacement parts will be warranted for a period of *ninety (90) days* provided they are installed and used in a manner authorized by NU-VU®.

## **WARRANTY LIMITATIONS:**

NU-VU® will pay for parts and labor under warranty if there is a defective component, but not for:

- Normal operational wear and tear on the following parts -
  - ┌ Light bulbs
  - ┌ Door gaskets
  - ┌ Door handles and catches
  - ┌ Fuses
- Damage attributable to customer abuse, including -
  - ┌ Proofer water pan allowed to run dry and burn.
  - ┌ Proofer fan motor damaged from not following outlined Dry-Out Procedure.
  - ┌ Lack of regular cleaning or maintenance.
- Power supply problems, including -
  - ┌ Insufficient or incorrect voltage.
  - ┌ Damage to electrical components caused by a power surge or spike.
  - ┌ Incorrect installation (i.e., equipment not supplied with separate neutral or ground as required, or incorrect location of high-voltage power leg for 240-volt 3-phase units).
  - ┌ Damage to electrical components resulting from use of an incorrect power supply cord or circuit breaker.
- Operational problems resulting from customer's failure to follow established procedures outlined in the Owner's Manual.
- A service call if nothing is found to be wrong (any returned parts work as per spec when tested).
- Recalibration of temperature and humidity controls (all controls are carefully calibrated and tested at our facility before shipment).
- Any equipment moved from the place of original installation unless NU-VU® agrees in writing to continue the warranty after the relocation.
- Ongoing operational adjustments due to changing environmental conditions or normal wear and tear.
- Any overtime charges. NU-VU® will pay straight time only for any work performed on NU-VU® equipment.

Products must be installed and maintained in accordance with NU-VU® instructions. Users are responsible for the suitability of the products to their application. There is no warranty against damage resulting from accident, abuse, alteration, misapplication, inadequate storage prior to installation, or improper specification or other operating conditions beyond our immediate control. Claims against carrier damage in transit must be filed by the buyer; therefore, the buyer **must inspect** the product immediately upon receipt.

***THE USE OF NON-OEM REPLACEMENT PARTS WITHOUT PRIOR EXPRESSED WRITTEN AUTHORIZATION FROM NU-VU® WILL VOID ANY AND ALL WARRANTIES.***

***THIS WARRANTY DOES NOT COVER ADJUSTMENTS  
DUE TO NORMAL ON-GOING USE OF THE UNIT!!!***

**PARTS RETURN PROCEDURE AND CONDITIONS:**

The following procedure shall be followed for the return of parts to the factory for credit consideration:

- All parts received by NU-VU® must have a completed RETURN AUTHORIZATION FORM as supplied by NU-VU® with the replacement part. An RGA # is require for parts being returned.
- Package all return parts securely so that in-transit damage cannot occur.
- Prepay shipment. Any parts returned collect will be refused by our receiving department. Credit will be considered on proper returns only.
- As soon as parts are tested and confirmed to be defective credit will be issued against them.
- If the engineering test shows the component is not defective and is in good working condition it may be returned to you along with your request for payment.

Please use this space to record the Model Number from the nameplate on the side of your NU-VU® equipment. You will need this number if you ever need to contact our Service Department concerning adjustments, replacement parts.

Model Number:   S     B   - \_\_\_\_\_